

Design and Implementation of a Small-scale, Standalone Hybrid Solar PV and Wind Energy System

DESIGN DOCUMENT

Team Number: sddec19-06

Client/Adviser: Dr. Venkataramana Ajjarapu

Team Members/Roles

Hussein Ghitan - Meeting Scribe, Design Simulator and Webmaster

Blaise Ronspies - Test Engineer

Adam Schroeder - Chief Engineer

Anna Schulte - Meeting Facilitator

Email: sddec19-06@iastate.edu

Team Website: <http://sddec19-06.sd.ece.iastate.edu/>

Table Of Contents

1 Introduction	2
1.1 ACKNOWLEDGEMENT:	2
1.2 PROBLEM AND PROJECT STATEMENT	2
1.3 OPERATIONAL ENVIRONMENT	2
1.4 INTENDED USERS AND USES	3
1.5 ASSUMPTIONS AND LIMITATIONS	3
1.6 EXPECTED END PRODUCT AND DELIVERABLES	3
2 Specifications and Analysis	4
2.1 PROPOSED DESIGN	4
2.2 DESIGN ANALYSIS	6
3 Testing and Implementation	7
3.1 INTERFACE SPECIFICATIONS	7
3.2 HARDWARE AND SOFTWARE	7
3.3 FUNCTIONAL TESTING	8
3.4 NON-FUNCTIONAL TESTING	8
3.5 PROCESS	8
3.6 RESULTS	9
4 Closing Material	9
4.1 CONCLUSION	9
4.2 REFERENCES	9

1 Introduction

1.1 ACKNOWLEDGEMENT:

Our team acknowledges Dr. Venkataramana Ajjarapu as our primary advisor for this project. Dr Ajjarapu has overseen and given assistance to this group, primarily in the form of technical advice and equipment. He has given us the necessary resources to learn what background material we will need regarding the solar panel power generation process. He has also provided us access to the EE 452 lab and all its equipment pertaining to our project. Our team also acknowledges Pranav Sharma, a graduate student who also serves as Dr. Ajjarapu's assistant, who will be providing our team with technical guidance and suggestions in regards to the technology involved in the project.

1.2 PROBLEM AND PROJECT STATEMENT

The objective of this project is to finish, improve upon, and design a new element for the EE 452 lab regarding solar panel power generation. The goal of this lab is to allow students to gain hands on experience working with the Photovoltaic (PV) array and how it is used to generate maximum power under changing weather conditions. We will ensure experimental functionality of the existing product, improve its safety and usability, and explore implementing a more useful load.

1.3 OPERATIONAL ENVIRONMENT

While the PV arrays remain outside in the courtyard area of Coover Hall to generate solar power, our small-scale house load will remain inside the lab room. The PV arrays are often shaded because of the surrounding building which shortens the amount of time that the solar panels can generate sufficient power. The whole project is about power, so the team members will always be in contact with the project's electrical component within the lab. Batteries, chargers, and the controller are powered at all times. Since the previous group did not completely test the system ensuring its operation, our group has to test and solve current issues within the system, including bad components and incorrect wiring.

1.4 INTENDED USERS AND USES

Our project is focused around implementing and improving on the PV generation labs for EE 452. Our design will be used by students who are trying to learn a basic understanding of solar generations and its capabilities. The uses of our design will be to help the students see a load model and experimentally verify power concepts covered in the course. The finished product will show the different elements of loads that would be seen on a grid: capacitive, inductive, and resistive. It will also allow for the students to model the power requirements of what would need to be supplied by the solar panel and the battery that are within the system. However, our project is a stand alone PV array system, meaning it's not connected to the grid. This results in limitations as load can only be powered if the batteries are charged or the sun is shining on the array.

1.5 ASSUMPTIONS AND LIMITATIONS

Assumptions: The physical structure of the system created by the previous group is not working correctly due to their time constraints for putting it all together. Currently the PV system is something that will be used only as a model. It is intended to function at a steady voltage supply and will be regulated for the safety of the circuitry. The solar power portion of this lab is meant to be used only when sufficient power is being produced by the solar panels, so labs and usage will be during the day. Currently, it is intended to be used for only one user/group at a time, but this can be modified in the future for better utility. This load will be stationary and is currently not made for frequent movement.

Limitations: The labs must work off of the already provided PV generation system. It must be able to fit in the establish space for different load models in the EE 452 lab. There must be accessible circuit components for any future replacements. The exact budget has not been defined at this point, but there is absolutely a cost limitation. The project is also weather dependent as the arrays require direct sunlight.

1.6 EXPECTED END PRODUCT AND DELIVERABLES

The end product that we will work on next semester is providing a platform that represents various capacitive, inductive and resistive loads. This will be used to experimentally verify concepts from EE 452. This has partially already been accomplished by creating a resistor bank with various resistances. We will look at adding scaled lights as resistors, electric motors for inductors, and batteries as

capacitors. We will add a defined I/O that will be compatible with the generation system available. It will also have modeling and test results showing how this load works in the defined system, and it will be applied into the existing PV labs and show how it is possible to power a home with this type of generation. This will come with instructions that will be used in lab documents, on how to connect this load to the generation and potential checks if there are problems. Dr. Ajarapu would like a functional product to be completed and tested before the end of April 2019 to allow the future students to have the opportunity to do the provided experiments. The product must be safe and useable in all foreseeable situations.

2 Specifications and Analysis

2.1 PROPOSED DESIGN

The proposed design of the PV system consists of multiple components, each playing a key role in the objective. A PV array will be connected to an MPPT. This MPPT will allow for the PV array to generate maximum power at all times. It does this iteratively by constantly changing the load seen by the PV array to get maximum power output. The ideal load for maximum power output depends upon irradiance and temperature, both of which vary each second. A buck/boost converter will be used in the circuit in order to change the voltage to whatever the load needs. It will power one of three loads as well as a battery for charging. The battery will be used to power the loads during times when the PV array is not capable of doing it on its own. This has been tested in Simulink, and the increase in efficiency and consistency that this design provides is significant. Updates to the design will be done first by simulation in Simulink. Then, our change will be slowly implemented into our physical system.

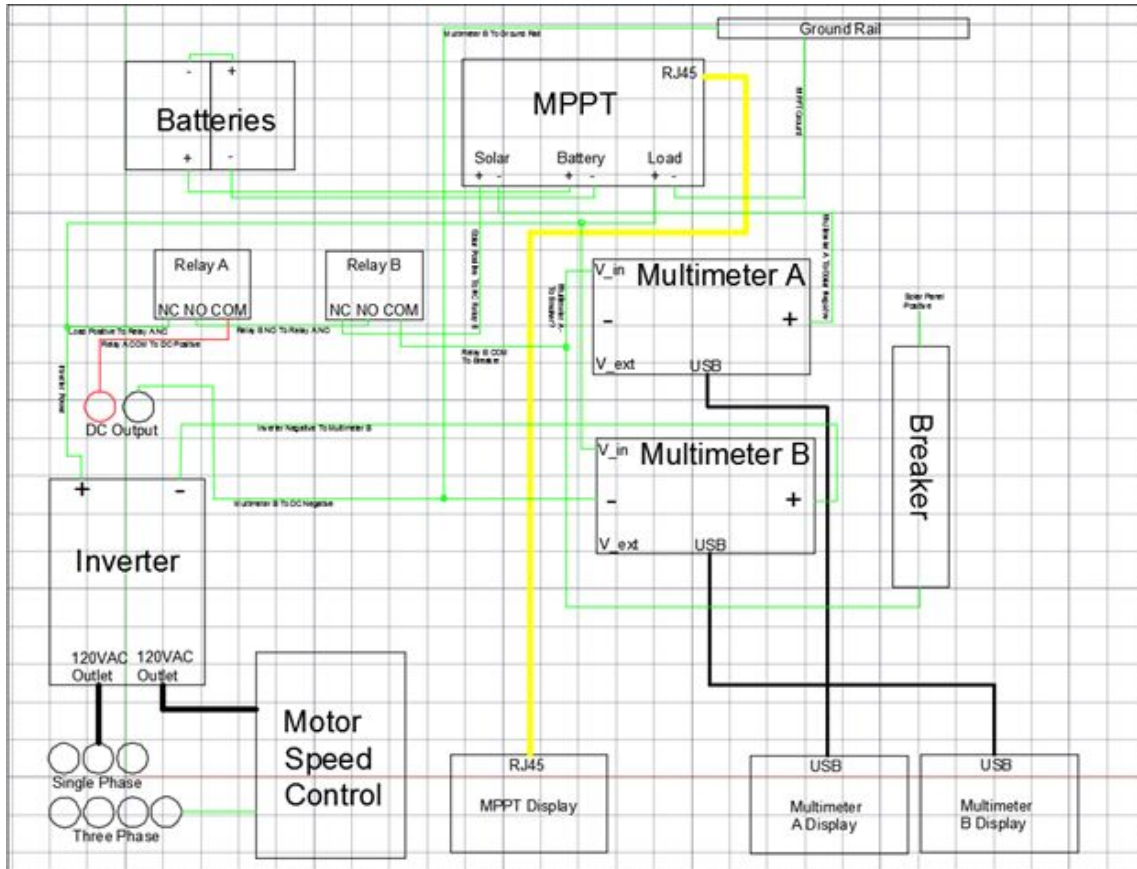

Even though the system works in Simulink, the previous group was unable to finish hooking all of the physical components up and test them. Our group is first focused on dissecting the physical components and testing each terminal to insure the proper connections. If bad connections are found they will be fixed, and if bad components are found they will be replaced. After all of this is completed we will be able to finally test and run the lab experiments in on the physical system. Making adjustments as needed. Finally we will then be able to add on to the working physical system by adding on a charging station that will be able to be accessed by students at all times during the day, even when not using it for a specific lab. In order to do this, the PV system has to be up and running at all times and the charging station must be plugged in to the single phase inverter of the system.

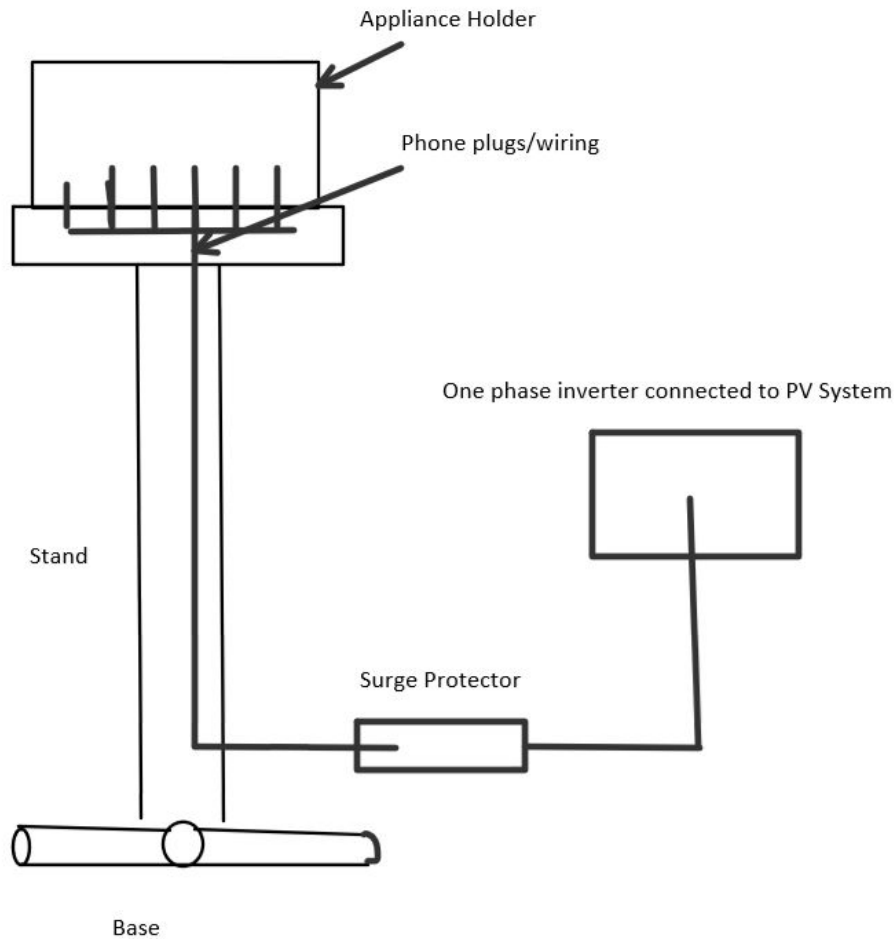

2.2 DESIGN ANALYSIS

Various components of our design as well as interactions between them have been thoroughly investigated using Simulink. The Simulink model will provide the PV graphs as well as the maximum power tracking point for every load. Some of the load connected to the model are simulated and have been successfully tested. Results still showed a great increase in efficiency and consistency of our proposed design of the simpler design. However, our team still working in the hardware system to verify some of the simulated values. The MPPT is responsible for greater power efficiency, which leads to few power losses due the energy transmitted from out of Coover where the PV arrays located to the controller input at the 452 lab. Also, the battery allows for 24-hour consistency. Weaknesses are few and relate only to the complexity of the circuit. More components and variables mean that one thing going wrong will ruin the entire system. It also means that the system will be reasonably more difficult to debug and fix.

3 Testing and Implementation

The hardware PV system will be tested based on two parts. Safety is the first and most important part of the project since the team deals with electrical power. The second is the accuracy and consistency of the results and values simulated by the model. All kinds of loads (DC and AC) will be tested by the end of this semester.

3.1 INTERFACE SPECIFICATIONS

Simulink will be the main program used to model our project on the software side to see if a hardware result is feasible. We have an accurate representation of the entire circuit created in Simulink with all the various components. When adding new components or changing variables, we can first change them in Simulink to simulate how the system will response before adding them to the physical setup. This will allow us to have safer, more reliable improvements to the system.

3.2 HARDWARE AND SOFTWARE

From the hardware side, currently, there are multiple safety hazards present in the setup. These include, but are not limited to: exposed wires, exposed connections, easily accessible hot points, and unintentional moving parts. These are very serious and could cause significant harm to a person or equipment. The team has also asked the ECpE department to relocate the PV arrays from its current spot to another place that have more irradiance far from the afternoon shadow. We also noticed the need to rewire the lab input power cables from the PV arrays so it has safe input to the controller and we will block off the system to make it harder to access. Still in the hardware side , the team had to replace the breaker as the old one tested failed and we also replaced one of the 12 volt batteries that found dead due to lack of charging by the previous teams that worked on the project. From the software side, Simulink and MATLAB have being used to simulate and model the PV system . Simulink is a tool in MATLAB that allows the user to be able to simulate, model and analyze systems in a safe environment. Simulink will allow us to simulate the amount of voltage and current across each component of resistor bank and be able to see the power consumption when each load is connected as well as the amount of solar energy needed to power that load. We will test every load in a safe environment before building the final model. Figure below shows the current Simulink model that we used to test different resistive loads with a solar panel.

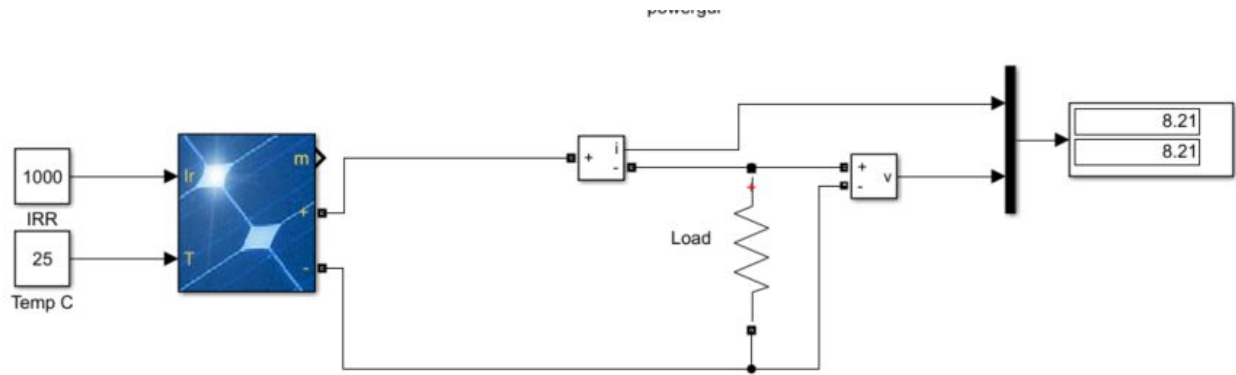

3.3 FUNCTIONAL TESTING

The project will be deemed a functional product when a DC output from the enclosure can be used to experimentally verify the maximum power point of the PV array. This can be verified by measuring a significant voltage at the relevant nodes on the enclosure. Testing has determined that previous project groups have gotten this far, and that decay or damage to parts is the only thing preventing a functional product. Going beyond basic functionality, the screens need to function, the inverter needs to be hooked up for DC/AC conversion, and a useful output needs to be implemented. Screen functionality is based on the screen itself, the wiring into the screen, and the arduino code. This is difficult to test and troubleshoot as it was not implemented by our group, and may need to be entirely redone if functionality cannot be achieved. The inverter is purchased, and should produce the correct output when given proper input. This can be easily tested when the input is ready. Useful output is currently being looked into, and will be considered successful if it can be used to experimentally verify a power concept in EE 452.

3.4 NON-FUNCTIONAL TESTING

Safety is always the number one priority of our project. Our finished product will not be implemented if it is unsafe, and in its current iteration this is the case. Though the enclosure itself is safe, this safety is easily bypassed. The lock can be opened with any coin, exposing all wiring. If the breaker fails, it cannot be safely removed without disconnecting the PV arrays. As well as safety, usability of the enclosure is lacking. Labelling is currently poor or non-existent, and it is very difficult for a user to understand how to operate the enclosure. The goal of our finished product is to be functionally user-proof. This will be determined by testing with multiple users, including those with no knowledge of the project.

3.5 PROCESS

A primary goal of our team is to give the enclosure more solid safety features to protect users. Currently, Facilities Planning and Management is installing more conduit from the enclosure to the PV arrays outside. This will prevent exposed wiring. We also would like to install a real lock on the enclosure, rather than a pseudo-lock that can be opened with a quarter. We will add labelling to switches, wiring, and safety features that is easily understood and very visible. We will also explore adding redundant safety features such as an external breaker or plug that will allow the enclosure to be easily disconnected from power completely. Faulty components will be replaced and previously designed experiments will be carried out using the enclosure.

3.6 RESULTS

A product will be created that can be used for multiple experiments in the EE 452 course. This product will be user-friendly and will not require any knowledge of power concepts to use. It will be safe and display safety warnings. Labelling will be clearly visible and easily understood. A useful function of some kind will be implemented by the project team.

4 Closing Material

4.1 CONCLUSION

As we have grown in our understanding and knowledge of this project we have identified many problems that we are working to fix. The main problem we have run across has been a bad breaker and battery that need to be replaced. After these components are replaced we will have to check the connections in the existing set up to avoid any potential failures of the system. Once the system is connected and working we will be able to test and make adjustments so that this project will be a helpful addition to the EE452 lab. After the lab is up and running we will be able to begin implementing our design for a charging station within the lab. When done, this lab will give students a better comprehension of the lab as well as an extra element to give students a better understanding of the PV system. Our goal for any addition is that it will enhance students' learning through a useful utility of the system.

4.2 REFERENCES

Senior Design Team sddec18-19. "Design and Implementation of a small scale stand alone Hybrid Solar PV and Wind Energy Generation system". *Iowa State University*. EE 491. <http://sddec18-19.sd.ece.iastate.edu/> . Dec 2018.

Anca D. Hensen, Poul Sorensen, Lars H. Hansen, Henrik Binner. "Models for a Stand-Alone PV System". *Riso National laboratory*. Roskilde. pp. 1-78. 2000.